

OPTICAL RADIATION MEASUREMENTS AT CNAM-INM

Jean Bastie¹

Abstract: The *Institut National de Métrologie du Conservatoire National des Arts et Métiers* (CNAM - INM), is the French national metrological laboratory in charge of realising the radiometric and photometric units. Cryogenic radiometers are recognised as the most accurate radiometric standards. Like most of the national standard laboratories world-wide, the CNAM-INM employs such an instrument as the basis for its optical radiation measurement scales. The photometric measurements are used to quantify the visual effect of radiation on the human eye. But, as eye is a very complicated organ and not the same for everybody, it is necessary to define a standard observer which is mainly described by the luminous efficiency function $V(\lambda)$. The two major photometric quantities for which our laboratory is realising standards are the luminous intensity and the luminous flux. In this paper is presented a review of the realisation of the luminous intensity unit.

Keywords: luminous intensity unit, optical radiation, measurement.

1. INTRODUCTION

The *Institut National de Métrologie du Conservatoire National des Arts et Métiers* (CNAM - INM), is the French national metrological laboratory in charge of realising the radiometric and photometric units. Cryogenic radiometers are recognised as the most accurate radiometric standards [1]. Like most of the national standard laboratories world-wide, the CNAM-INM employs such an instrument as the basis for its optical radiation measurement scales [2].

The principle of this apparatus is very simple and more than 100 years old. It is based on the electrical substitution. In a first step, the optical radiation to be measured is put into an absorbing cavity giving a rise in temperature of this cavity. In a second step, the optical radiation is replaced by an electrical heating in order to get the same rise in temperature. If the radiometer would be perfect, the optical power will be equal to the electrical power. In practice we have to do several corrections to get the accurate results. Working at low temperature allows to increase the responsivity of the device

and to reduce dramatically the correction factors and their associated uncertainties.

All the radiometric and photometric measurements carried out in our laboratory are linked to this primary standard. The measurements described in this paper deal mainly with photometric quantities and quantities which are needed to realise the photometric base unit, the candela.

The photometric measurements are used to quantify the visual effect of radiation on the human eye. But, as eye is a very complicated organ and not the same for everybody, it is necessary to define a standard observer which is mainly described by the luminous efficiency function $V(\lambda)$ [3]. The two major photometric quantities for which our laboratory is realising standards are the luminous intensity and the luminous flux.

2. THE CRYOGENIC RADIOMETER

2.1. Characteristics of the cryogenic radiometer

¹ Conservatoire National des arts et métiers, 292 rue Saint Martin 75003, Paris, France.
Phone : +33 1 40 27 20 25, fax : +33 1 42 71 37 36, e-mail : bastie@cnam.fr

The cryogenic radiometer installed at the CNAM-INM is the LaseRad system from Cambridge Research Instrumentation [4]. Design specifications for the laboratory provide an operating power range around 1 mW, and enable measurements to be carried out between 250 nm – 2000 nm.

2.2. Description of the system

The design of the cryogenic radiometer is shown in figure 1. Its basic element is the highly absorptive cavity, which heats up when it is either irradiated or electrically heated. It is constructed of a copper tube and contains an inclined plane to contribute to the absorption of the incident radiation. Its interior is

coated with a specular black paint of high absorption.

To measure the radiant power with the electrical substitution method, the radiant heating is replaced by electrical heating to produce an equivalent temperature change. For doing that, thin film heaters are placed on the inclined plane within the cavity tube and the temperature is sensed with germanium resistance thermometers.

The cavity is mounted horizontally and is thermally linked to the helium liquid reservoir. Both are placed in a high-vacuum enclosure, which is closed by a quartz window. To minimise reflective losses, this window can be conveniently adjusted to the Brewster angle.

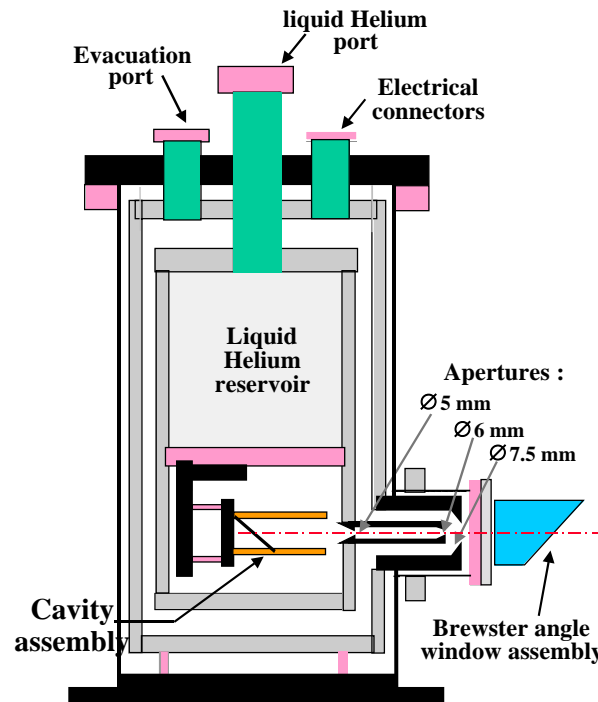

Figure 1- Schematic drawing of the cryogenic radiometer.

Considering the shape and the location of the cavity, the LaseRad can only be used with collimated laser beam of diameter up to 2 mm. Nevertheless the use of linearly polarised laser beam passing through the Brewster angle window has a great advantage : it allows one to obtain a window transmission very close to one.

2.3. Correction factors on the radiometric power measurements with the cryogenic radiometer

To know accurately the radiant power in the laser beams, which are used in subsequent transfer detector calibration, various corrections must be applied to the cryogenic radiometer laser

power measurement. At the CNAM-INM, we have developed subsidiary set-ups to study carefully and individually each correction factor and its related uncertainty, at all measurement laser wavelengths used for calibrations.

One of the main corrections depends on the residual cavity reflectance. It has been measured by removing the cavity and mounting it at the port of an integrating sphere [5]. The window transmission and reflection are also studied by removing the window from its support. Another correction depends on the non-equivalence between radioactive and electrical heating, it is evaluated by

measuring the electrical power required by two different heaters to achieve the same temperature. The last important correction concerns the electrical calibration of the cryogenic radiometer for the measurement of the electrical power [6].

Finally, the global correction is compounded by these different corrections and depends on the measurement wavelength. As an example, these different correction factors obtained at 543 nm are indicated in table 1, as well as the uncertainty on their determination.

Table 1 – Correction factors and uncertainty budget of the CNAM-INM cryogenic radiometer

Measurement	Correction	Relative uncertainty (1σ)
Cavity absorptance	0.99988	1×10^{-5}
Window transmission	0.99974	3×10^{-5}
Heating non-equivalence	1.00000	1×10^{-5}
Electrical power measurement	1.00000	3×10^{-5}
Global correction	0.99960	5×10^{-5}

3. REALISATION OF THE LUMINOUS INTENSITY UNIT

3.1. Principle of measurement

The present definition of the candela is : The candela is the luminous intensity, in a given direction, of a source that emits a monochromatic radiation of frequency 540.10^{12} hertz and that has a radiant intensity in that direction of $1/683$ watt per steradian [7]. It can be also written in a numerical form according to the following equation.

$$I_v = K_m \int_{\lambda} I_{e,\lambda}(\lambda) \cdot V(\lambda) \cdot d\lambda$$

This definition gives only a numerical relationship between the luminous quantities and the radiometric quantities. The luminous intensity I_v is linked to the spectral radiant intensity distribution $I_{e,\lambda}(\lambda)$, weighted by the $V(\lambda)$ function and multiplied by K_m . $V(\lambda)$ is the spectral luminous efficiency of standard observer defined by the CIE in 1924 and K_m is the maximum luminous efficiency which fixes the relationship between luminous and radiant quantities. By definition K_m is equal to 683 lm/W .

The principle used in our laboratory to realise the candela is directly linked to

the definition. The source to be calibrated in luminous intensity I_v , irradiates through a filter, a radiometer able to measure the irradiance it receives, E_e in an absolute way, in Wm^{-2} . The transmittance of the filter $\tau(\lambda)$ slightly corrected by the relative spectral responsivity of the detector is proportional to the $V(\lambda)$ function : $\tau(\lambda) = \tau \cdot V(\lambda)$. In these conditions the luminous irradiance is given by :

$$E_v = (K_m \cdot E_e) / \tau_0 \quad (1)$$

In practice, it is not possible to realise a filter which match perfectly well $V(\lambda)$ and it is necessary to define the spectral matching factor to take into account for the discrepancy between the perfect and the realised filter. This matching factor is defined by the following equation:

$$F = \frac{\int_{\lambda} S_{e,\lambda}(\lambda) \cdot \tau(\lambda) \cdot d\lambda}{\int_{\lambda} S_{e,\lambda}(\lambda) \cdot V(\lambda) \cdot d\lambda} \quad (2)$$

With : $S_{e,\lambda}(\lambda)$ relative spectral distribution of the source to be calibrated,

$\tau(\lambda)$ transmission of the real filter,

$V(\lambda)$ spectral luminous efficiency function.

3.2. Standard photometers

For realising the luminous intensity unit according to the principle described previously, it is necessary to built an experimental set-up able to convert radiant intensity into luminous intensity. In our laboratory we use standard photometers directly calibrated by comparison to the cryogenic radiometer to do this conversion.[8] These standard photometers are made with a large area silicon photodiode, a set of coloured glass filters which adjust the spectral responsivity of the detector to match the $V(\lambda)$ function, and a calibrated aperture. All these components are put together in a temperature controlled housing (figure 2).

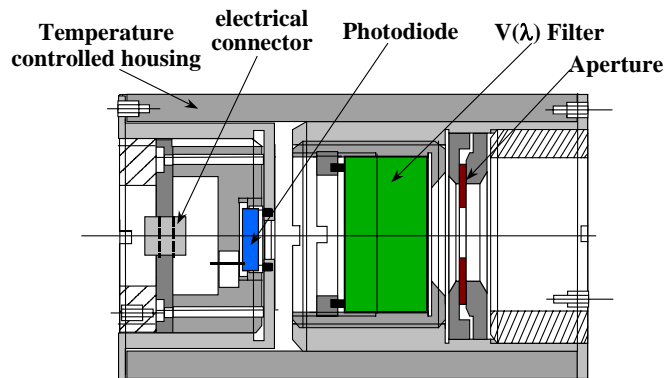

Figure 2 – Schematic drawing of a standard photometer.

To be able to characterise these photometers we have had to realise experimental set-up for measuring the spectral responsivity of detectors, the spectral transmittance of filters and the area of apertures [9].

3.3. Spectral responsivity measurement

As our cryogenic radiometer can only be used with laser radiation, the

calibration of the detector in spectral responsivity is carried out in a two steps method. The first step is the absolute calibration at some laser wavelengths by direct comparison to the cryogenic radiometer. The experimental set-up used for these measurements is shown in figure 3.

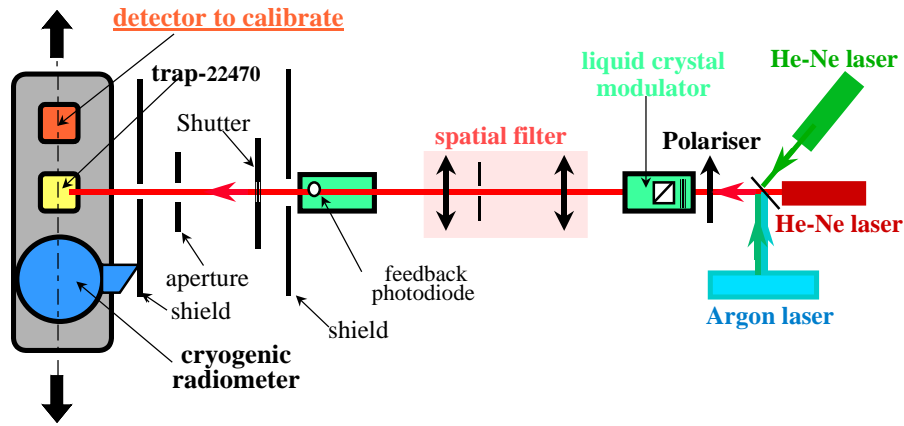

Figure 3 – Experimental set-up for calibrating detectors against the cryogenic radiometer

The light emitted by the laser is power stabilised by a feedback photodiode and a liquid crystal modulator. The achieved stability is in the range of few parts in 10^5 during the time needed for a comparison, typically 15 minutes. The spatial filter adjusts the beam size to the right diameter and removed the stray light. The test detector is compared to the cryogenic radiometer by putting, successively the two detectors into the laser beam using a translation stage. Another known detector is also measured at the same time in order to check the validity of the results.

The uncertainty budget of each calibration comprises several components, which are divided in three groups : the uncertainties of the measurement of the transfer detector photo-current, the uncertainties related to the experimental arrangement, and the uncertainty of the cryogenic radiometer itself. In the first group, the major contribution to the uncertainty is from the calibration of the current to voltage converter used to measure the photo-current. In the second group, the major contribution is associated with the corrections due to the difference in diameter between the detectors and the cavity of the radiometer (referred to as the diaphragm effect). The resulting global uncertainty is less than 1 part in 10^4 , but it must be compounded with the repeatability of the calibration

measurement, which depends on the kind of transfer detectors. At present time, our best transfer detectors are three element Si photodiode reflectance traps, which have a highly stable responsivity. The uncertainty budget for this kind of detector is presented in table 2. They are calibrated with a global standard uncertainty comprised between 1 or 2 parts in 10^4 , only in the visible range [10].

Table 2 – Uncertainty budget for the calibration of a trap detector at 543 nm

Source of uncertainty	Relative uncertainty (1σ)
Cryogenic Radiometer	0.5×10^{-4}
total uncertainty	
Diaphragm effect	0.1×10^{-4}
Current/voltage converter calibration	1×10^{-4}
Repeatability of the measurement	0.8×10^{-4}
Total uncertainty (quadrature Sum)	1.3×10^{-4}

To extend the spectral responsivity calibration of the detector all over the spectral range, in a second step we use a

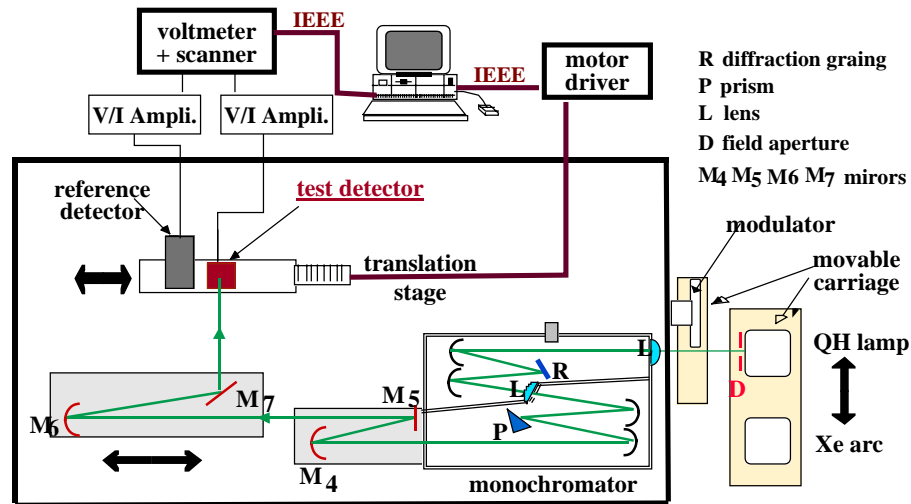

Figure 4 – Experimental set-up for measuring detector relative spectral responsivity.

The measurement of the relative spectral responsivity is carried out by comparison of the response of the photodiode to that of a reference detector, when they are irradiated by the same monochromatic flux. The reference detector is a non selective cavity shape pyroelectric detector. The set-up shown in figure 4 is built around a double monochromator with a grating and a prism. This arrangement allows to cover the spectral range between 200 and 2500 nm without any dismantling of the device.

The optical set-up at the exit of the monochromator had been carefully studied to obtain the image of the entrance aperture on the surface of the detector to be calibrated. The luminous sources used for this study are either a quartz halogen lamp for the visible and the near infrared range or a xenon arc for the near UV and the visible range.

In this calibration, the major cause of uncertainty is coming from the repeatability of measurements. The responsivity of the cavity shape pyroelectric detector is rather low and the flux available at the exit slit of the monochromator is not very important. So

the signal to noise ratio is usually in the range of 10^3 giving a standard uncertainty of about $2 \cdot 10^{-3}$ in the visible range used for photometer calibration.

3.4. Characterisation of the $V(\lambda)$ filters

Using the relative spectral responsivity measured on the Hamamatsu photodiode selected for realising the photometers and the $V(\lambda)$ function, we have determined the theoretical filter to match $V(\lambda)$. From glass filter catalogue from Schott, we have selected some glasses, which seems appropriate for approximating the ideal filter. Then, we have determined the number of suitable filters and calculated their thickness to approximate the ideal filter. The calculated filter was realised and measured on our experimental set-up for filter transmittance measurement. The set-up used to study the transmittance of filters is shown in figure 5. It is able to measure regular transmittance in the spectral range from 280 to 2500 nm.

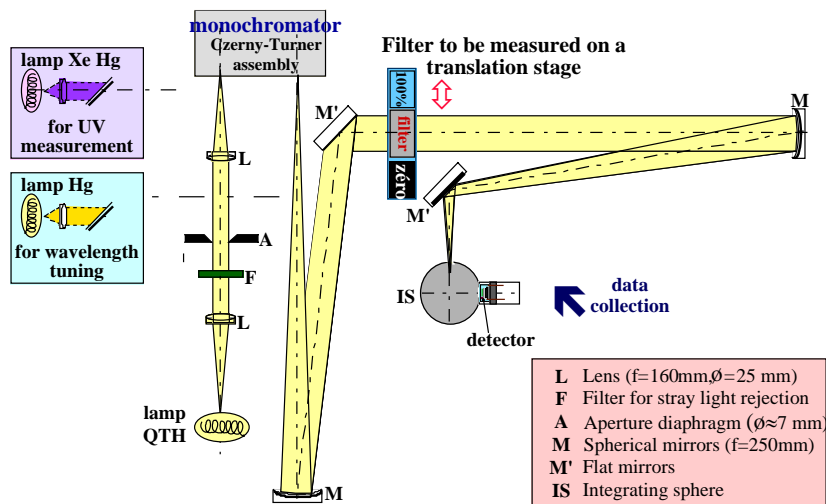

Figure 5 – Experimental set-up for measuring filter regular spectral transmittance

This spectrophotometer is a single beam, single grating, laboratory built apparatus. It is constructed with, as main piece of equipment, a very high resolution monochromator, which can be fitted, according to the spectral range, with various diffraction gratings. The irradiance for the visible and infrared range, at the entrance slit, is obtained by imaging the filament of a quartz halogen lamp with two symmetrical lenses. Between these lenses there is an aperture. The position and the size of this

aperture are such that it is imaged first on the grating and next on the filter under calibration. In this way, the measurement area on the filter is perfectly well defined and irradiated homogeneously. The optical set-up at the exit slit of the monochromator gives a parallel beam at the position where the filters are measured.[11] The results of the study of the $V(\lambda)$ filter is shown in this figure 6. In the visible spectral range the relative standard uncertainties are usually less than 10^{-3} .

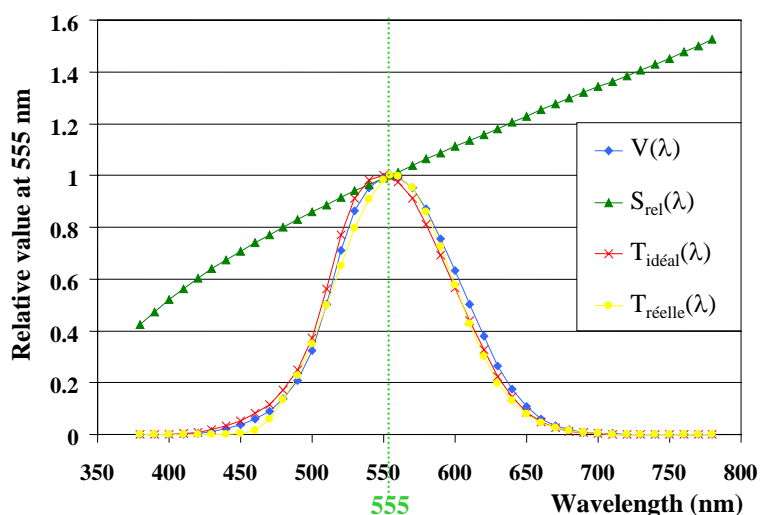

Figure 6 – Transmittance of the realised $V(\lambda)$ filter.

3.5. Aperture measurements

The apertures mounted in the photometer are manufactured in a thin sheet of blackened nickel of 25 μm in thickness, with two different nominal diameters of 10 and 12 mm. To measure the area of each aperture we have used a microscope, equipped with two

microscopes, equipped with two

translation stages X and Y. With this device we determine the X and Y position of 36 points on the edge of the aperture. These points are approximately distributed each 10° around the aperture. Using a least square fit developed in our laboratory, we calculate the position of the centre of the best circle and its radius [12] [13].

The results of these measurements are given in table 3. For all apertures measured the values of radius are very close to the nominal value and the relative standard uncertainties on the surface are in the range of approximately 2 to $5 \cdot 10^{-4}$.

Table 3 - Measurements of the aperture surface.

Aperture	Radius R (mm)	Surface (mm ²)	σ_s / S
D 11	5.005	78.710	$2.5 \cdot 10^{-4}$
D 12	5.006	78.723	$3.1 \cdot 10^{-4}$
D 21	6.002	113.171	$2.3 \cdot 10^{-4}$
D 22	6.005	113.286	$4.8 \cdot 10^{-4}$

3.6. Photometer calibration

The components previously studied have been put together in a temperature controlled housing to realise a photometer. The complete photometer

was calibrated directly, for the measurement of radiant power by comparison with the cryogenic radiometer at 5 wavelengths. The results of this calibration are shown in table 4.

Table 4 - Absolute responsivity measurements of the photometer using the cryogenic radiometer.

λ nm	flux mW	Responsivity A/W	Standard deviation
488.12	161.31	0.02019	$3 \cdot 10^{-5}$
514.36	154.89	0.06183	$1 \cdot 10^{-5}$
543.36	153.64	0.11302	$2 \cdot 10^{-5}$
611.80	159.39	0.05820	$5 \cdot 10^{-5}$
632.81	181.64	0.02668	$2 \cdot 10^{-5}$

Using the absolute spectral responsivity measured against the cryogenic radiometer for the 5 wavelengths and the relative spectral responsivity of the photometer determined previously we have calculated its luminous responsivity. This luminous responsivity was $1.815 \cdot 10^{-4}$ A/lm with a standard deviation of $2.2 \cdot 10^{-3}$.

3.6. Luminous intensity measurement

The standard photometers are designed to measure illuminance in the plane of its entrance aperture. So to calibrate incandescent standard lamps in luminous intensity we have to measure accurately the distance between the filament of the lamp and the aperture of the photometer. This is done on a photometric bench with a very good quality ruler and precision indexes.

To check our photometer we have calibrated 2 standard lamps OSRAM Wi 41/G on our photometric bench. The results are given in table 5. The 2 first columns for the lamp n° 926 shows the results of 2 separate calibrations carried out in the same conditions for the photometer (reproducibility check). In that measurement the aperture used was 10 mm in diameter. The 3rd measurement with the lamp n° 926 was carried out with an aperture of 12 mm in diameter to

check the effect of this parameter on the measurements. The measurements with the lamp n° 963 were carried out respectively with the aperture of 10 and 12 mm in diameter. These results have been compared with our maintained luminous intensity unit realised in 1985 using an electrically calibrated radiometer at room temperature. The discrepancy between the old and the new realisation of the candela is about 0.7%.

Table 5 - Results of the calibration of 2 standard lamps.

Lamp number	926	926	926	963	963
I lamp (cd)	234.3	234.3	234.3	236.4	236.4
measure (cd)	232.6	232.5	233.0	234.9	235.1
I mean (cd)	232.7			235.0	
Relative deviation	0.7%			0.6%	

3.7. Uncertainty budget

The components of the present uncertainty budget are detailed in table 6. The first group of components are related to the geometrical parameters and are reasonably small. The colour matching factor and the spatial responsivity are related to the photometer itself and include mainly the uncertainty in the relative spectral responsivity measurements and the filter transmittance measurements. Their high values are mainly due to the inter-reflection between

the filter and the detector, which are difficult to evaluate. The uncertainties on electrical measurements for the photometer as well as for the lamp are reasonably small. The uncertainty on the mean luminous responsivity, which includes mainly the uncertainty on the absolute and relative spectral responsivity of the photometer is the highest. The present total standard uncertainty is 0.32%.

Table 6 – Uncertainty budget for the realisation of the candela.

Solid angle	
Aperture surface	0.03 %
Distance	0.02 %
Colour matching factor	0.19 %
Spatial responsivity	0,10 %
Photometer current	
Amplifier resistance	0.04 %
Voltmeter	0.001 %
Lamp intensity	
Voltage for lamp current	0.001 %
Current measurement resistance	0.04 %
Mean luminous responsivity	0.22 %
Global uncertainty (1σ)	0.32 %

Recently we have developed new standard photometers using trap detectors instead of plane detectors in order to reduce the inter-reflection between the filter and the detector. The work is now in progress and we hope to reduce the present uncertainty by a factor of 2 to 3.

4. LUMINOUS FLUX MEASUREMENT

4.1. Principle of measurement

Traditionally a luminous flux standard lamp is a lamp for which the luminous flux is measured in the space all around it. From the luminous intensity, the luminous flux is defined by

$$d\Phi = I \cdot d\Omega \quad (3)$$

According to this definition, the luminous flux emitted in all the space is determined by integrating the luminous intensity over the full solid angle, 4π steradian.

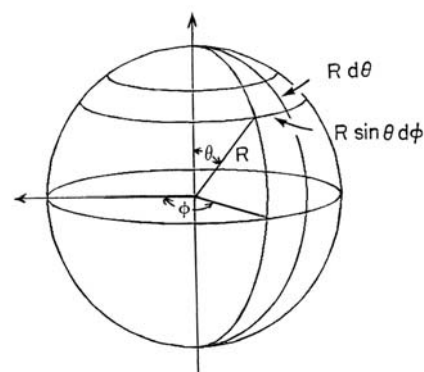

Figure 7 - Trigonometrical expression of the solid angle.

The element of solid angle $d\Omega$ is defined in figure 7. It can be expressed trigonometrically by the following equation.

$$d\Omega = \sin \theta \cdot d\theta \cdot d\phi$$

with $d\Omega$ element of solid angle,
 θ elevation angle with $\theta = 0$ at zenith
 ϕ azimuth angle

The luminous flux is :

$$\Phi = \int_0^{2\pi} \int_{-\pi/2}^{+\pi/2} I(\theta, \varphi) \cdot \sin \theta \cdot d\theta \cdot d\varphi$$

The luminous intensity distribution can be measured with a goniophotometer. The performances of this apparatus must be as high as possible in order to keep the added uncertainties lower or at least of the same order of magnitude as the uncertainties achieved in realising the candela.

The goniophotometer : To realise the luminous flux unit, the lumen, starting from the luminous intensity units we have built a large size goniophotometer (7 m diameter) [14].

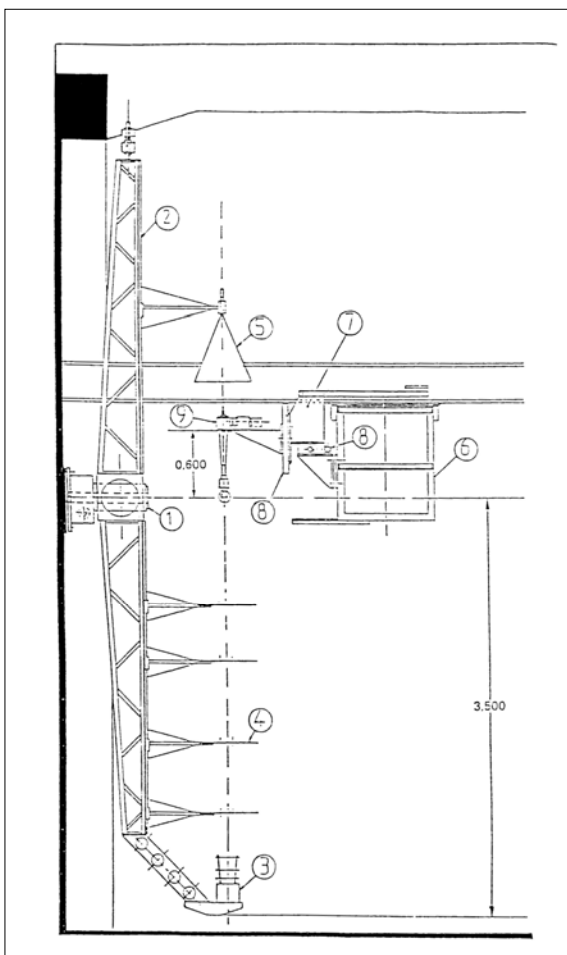

Figure 8 – Schematic drawing of the goniophotometer.

To be stable a standard lamp must be operated in a prescribed burning position, generally vertical, cap up. For this reason the goniophotometer realises the spatial measurement of the luminous intensity measurement according to the following method : the lamp can be rotated around its vertical axis over a full circle (360°). The photometer can be rotated in a vertical plane containing the axis of the lamp. Its rotation is only a half of a circle (180°). The lamp is put at the centre of the circle described by the photometer. These two rotations allow measuring the luminous intensity distribution of the lamp all over the space around it.

The main characteristics of the apparatus are :

Distance between source and detector : 3 400 mm

Photometer $V(\lambda)$ corrected, diameter: 60 mm (angular measurement 1°)

Speed of motion of the detector : 4°/s

Uncertainty on the angular setting : 0.02°

For practical measurements, the lamp is set at an azimuth angle and the photometer is moved on half a circle, taking a measurement every 3°. Then the lamp is rotated by an angle of 6° and the motion of the photometer starts again in the reverse direction. The measurement continues until all the sphere has been described giving a total number of 3 600 luminous intensity data and the same number of angle data.

The photometer is calibrated using luminous intensity standard lamps. For accurate measurements the data regarding the luminous intensity and the angle must be taken exactly at the same time. In order to keep the time of measurement at a reasonable level (about 1 hour) the measurements are taken “on the fly”.

The motorization of the rotation of the lamp and of the photometer is done by stepping motors connected with step down gears free from play. With stepping motors it is possible to have, with the

same electronic device, the motor rotation and the angular positioning by pulse counting. The needed data to realise a standard lamp of luminous flux are the electrical parameters of the lamp (current, voltage) which must be known and stable with an accuracy better than 10^{-4} and the luminous intensity in all the directions. The luminous intensity measurement is

done with a silicon photodiode very well $V(\lambda)$ and cosine corrected and its temperature is controlled within $\pm 0.1^\circ\text{C}$. The photoelectric current is measured using a high quality current to voltage converter. The block diagram of the data processing system of the goniophotometer is shown in figure 9.

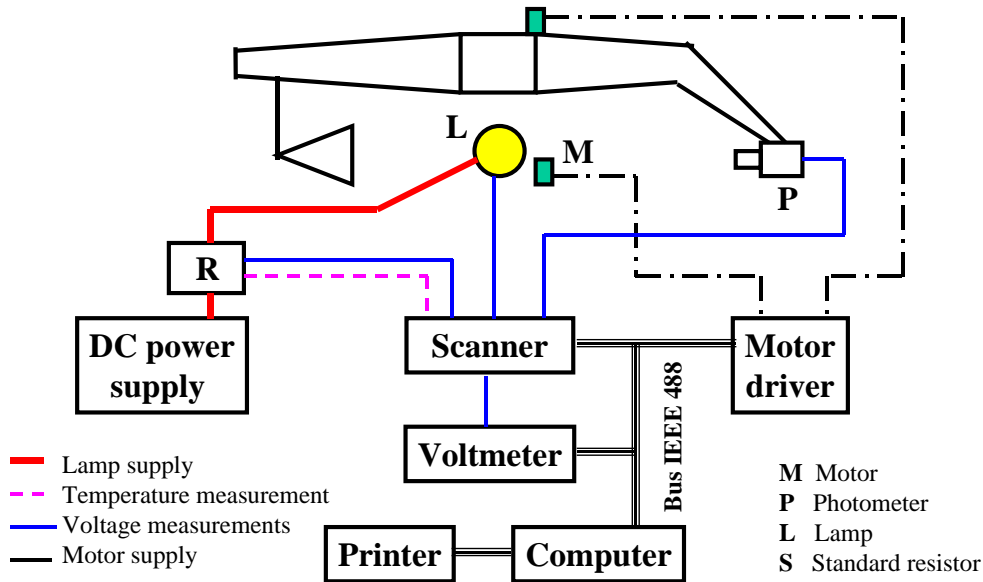

Figure 9 – Data processing block diagram of the goniophotometer.

All the electrical information are sent to a scanner which selects the requested data to be sent to a voltmeter according to the acquisition programme. The information related to the angular positioning of the goniometer directly read on the motor driver at the same time as the relevant electrical information.

The total flux emitted by the lamp is calculated by integrating the luminous intensity distribution over a complete sphere (4π steradians) according the equation :

$$\Phi = \int_0^{2\pi} \int_{-\pi/2}^{+\pi/2} I(\theta, \varphi) \cdot \sin\theta \cdot d\theta \cdot d\varphi$$

- With : Φ luminous flux
- $I(\theta, \varphi)$ Luminous intensity distribution
- θ elevation angle, with $\theta = 0$ at zenith
- φ azimuth angle

Incandescent standard lamps : The standard lamps usually used for maintaining the luminous flux unit, the lumen, are incandescent lamps specially manufactures in order to be stable and reproducible, with a smooth intensity distribution. They are supplied by DC current. For this type of lamps the temporal aspects of the “on the fly” measurements is relatively easy to take into account for. The time constant of the equipment used for measuring the photocurrent of the detector must be fast enough compared with the speed of variation of luminous intensity during measurements [15].

To illustrate the performances of our goniophotometer, some results concerning six high quality standard lamps are given. Before and after the series of measurement, the photometer was calibrated using luminous intensity standard lamps. The date of these

measurements were respectively March 26 and April 28; the measured responsivity were 7.916 mV/cd and 7.932 mV/cd. The relative difference $2.0 \cdot 10^{-3}$ of these two values is of the same order of

magnitude as the uncertainty on these measurements. During the series of measurements each lamp was measured 5 times and the results are given in table 7.

Table 7 – Example of luminous flux measurements.

Ref lamp	Mean luminous flux (lm)	Relative standard deviation (%)
185	2408.6	$5.2 \cdot 10^{-4}$
421	2407.5	$6.5 \cdot 10^{-4}$
423	2557.5	$4.3 \cdot 10^{-4}$
425	2875.5	$6.4 \cdot 10^{-4}$
428	2576.7	$8.0 \cdot 10^{-4}$
429	2549.1	$6.2 \cdot 10^{-4}$

As it can be seen on this table, the repeatability of measurements is quite satisfactory. At present time, with this type of lamps the performance of this equipment are very satisfactory and the achievable uncertainty is $5 \cdot 10^{-3}$. In this uncertainty, as said previously, $3 \cdot 10^{-3}$ are coming from the realisation of the luminous intensity unit.

general solution to this problem has been described and the study of the quality of the results of the luminous flux measurement has to be done with the equipment used on the experimental set-up. With our present equipment the achievable uncertainty are in the range from 1% to 5% depending the type of light sources measured.

Fluorescent standard lamps : Most of the users are interested in the total flux emitted by various type of discharge lamps because they are commonly used in lighting applications due to their high efficiency. Usually these lamps are supplied directly by the electric distribution network associated with a ballast. In that conditions, the light output of the lamp is modulated at a frequency which dependant on the frequency of the electric distribution network and on the type of ballast used. For classical ballast (ferromagnetic) the frequency modulation is the double of the frequency of the network, in Europe 50 Hz. For the electronic ballast the frequency is usually in the range of few kHz, depending on the type of device used. Also the temporal aspects of the data acquisition in the “on the fly” measurements has to be carefully taken into account for getting correct measurements [16]. Up to now no ENGEVISTA, v. 7, n. 2, p. 4-18, dezembro 2005

5. CONCLUSION

It is a long way between the primary standard, the cryogenic radiometer, and the lamps used to transfer the luminous flux unit in the industry. It involves a lot of specific measurements in almost all the fields of activities of the radiometry, spectro-radiometry, photometry and spectro-photometry. To be able to have luminous flux standards perfectly traceable to the primary standard of radiation, the cryogenic radiometer, we need the following capabilities of measurements :

- Electrical power measurement traceable to the SI units of current and voltage for the comparison of optical and electrical power.
- Measurement of reflectance in order to determine the absorption of the cavity of the cryogenic radiometer.

- Measurement of the spectral responsivity of detectors in order to characterise the detector used in the photometer.
- Measurement of the linearity of the detectors used in the photometer.
- Measurement of filters in order to be able to realise good $V(\lambda)$ adjustment of the photometer
- Measurement of spectral distribution of sources in order to be able to calculate the colour correction matching factor of the photometer.
- Measurement of the surface of the aperture limiting the flux entering into the photometer.
- Characterisation of the goniophotometer.

Due to this large quantity of extra measurements needed to realise luminous flux standard lamps, the traceability is not very easy to determine and need to be carefully check at each step. Another consequence of that is also the deterioration of the uncertainty along the chain. Starting with an uncertainty of approximately 0.01% at top of the calibration chain we have only 0.5% at the end for the realisation of luminous flux standard lamps.

Nevertheless, in spite the need of numerous additional measurements for characterising the photometers and the goniophotometer, the achievable uncertainty is perfectly acceptable for most of the common use. For luminous flux measurement, after the realisation of the unit with the goniophotometer, the transfer to user is done by comparison of the test lamp to the standard lamps using an integrating sphere. This comparison which can be very fast compared to the measurement with a goniophotometer, can be made with a very small additional uncertainty if the standard lamp and the test lamp are of the same type.

6. REFERENCES

[1] J.E. MARTIN, N.P. FOX and P.J KEY., A Cryogenic Radiometer for ENGEVISTA, v. 7, n. 2, p. 4-18, dezembro 2005

Absolute Radiometric Measurements, Metrologia, **21**, 147-155, 1985.

[2] O. TOUAYAR, J-M. COUTIN and J. BASTIE, Le radiomètre cryogénique : référence primaire du BNM-INM pour les mesures de rayonnements optiques, Bulletin du BNM, n° 117, volume 1999-3, pages 35-44.

[3] Photometry – The CIE system of physical photometry, Standard CIE S 010/E : 2004

[4] C.C. HOYT and P.V. FOUKAL, Cryogenic Radiometers and their application to Metrology, Metrologia, **28**, 163-167, 1991

[5] O. TOUAYAR, B. ROUGIÉ, J.M. COUTIN and J. BASTIE, Measurement of the reflectance of the INM cryogenic radiometer cavity at several wavelengths, Metrologia **35**, 387-391, 1998

[6] O. TOUAYAR and J. BASTIE, Les références radiométriques à l'INM, radiomètre à substitution électrique cryogénique. Comptes rendus du 6^{ème} Congrès International de Métrologie, 1993.

[7] Conférence Générale des Poids et Mesures (CGPM) : Comptes Rendus de la 16^{ème} Séance, 1979.

[8] A. KATNAH, Une nouvelle matérialisation de l'unité d'intensité lumineuse « la candela » basée sur le radiomètre cryogénique. Thèse de doctorat 1997.

[9] A. KATNAH, J-M. COUTIN et J. BASTIE, Realisation of the candela based on a cryogenic radiometer, Proceedings of the 24th CIE Session 1999, Warsaw (Poland), pages 184-188.

[10] J-M COUTIN, O TOUAYAR and J. BASTIE, The using conditions of the BNM-INM cryogenic radiometer as the basis for the French optical radiation measurement scales, Proceedings of the 24th CIE Session 1999, Warsaw (Poland), pages 222-224.

[11] P. LECOLLINET and J. BASTIE, Mesure des facteurs de transmission de filtres optiques au BNM-INM, Actes des

conférences Métrologie 1997, Besançon, France, pages 343-347.

[12] A. RAZET, Résolution analytique d'un cercle de moindres carrés pour une utilisation en interférométrie, Bulletin du BNM, n° 108 avril 1997, pages 39-48.

[13] A. RAZET, Etalonnage de diamètres de diaphragmes pour des mesures radiométriques, Bulletin du BNM n° 120 volume 2001-2, pages 27-33.

[14] J. BASTIE, Luminous flux measurement at the BNM-INM photometry laboratory, Proceedings of Light & lighting 2000, Bucharest (Romania).

[15] J. BASTIE, B. ANDASSE and R. FOUCART, Luminous flux measurements with a goniophotometer; study of time effects on data collection. Proceedings of the 22nd CIE Session 1991, Melbourne (Australia), pages 44-47.

[16] J. BASTIE, Mesure du flux lumineux des lampes à décharge haute pression par goniophotométrie, LUX La revue de l'éclairage n° 153, mai-juin-juillet 1989, pages 15-18.